



- According to IEC/EN 60 947-1, IEC/EN 60 947-4-2
- For speed control of 3-phase asynchronous motors up to 5.5 kW
- Speed adjustment by potentiometer on the front
- Additional galvanic separated control input for external speed control 0 ... 10 V, 0 ... 20 mA, 4 ... 20 mA
- $U_{min}$  and  $U_{max}$  setting accessible behind screw cover
- Large motor voltage range
- Integrated temperature monitoring
- Fulfills the EMC requirement according to IEC/EN 61 000-6-4 limit class B, therefore **screened wires are not necessary** between motor and controller
- 2 changeover monitoring contacts
- LED indicators for alarm and status
- Connection for thermistor to monitor temperature
- 100 mm, 122 mm and 168 mm width

**Approvals and marking**



**Application**

- Speed control of fans and pumps.
- Speed control only works if the torque of the driven load rises with a quadratic function relative to the speed. Usually this is given with fans and pumps. Suitable motors: Asynchronous motors designed for voltage control (Rotor material Silumin or similar, isolation class F)

**Function Diagram**

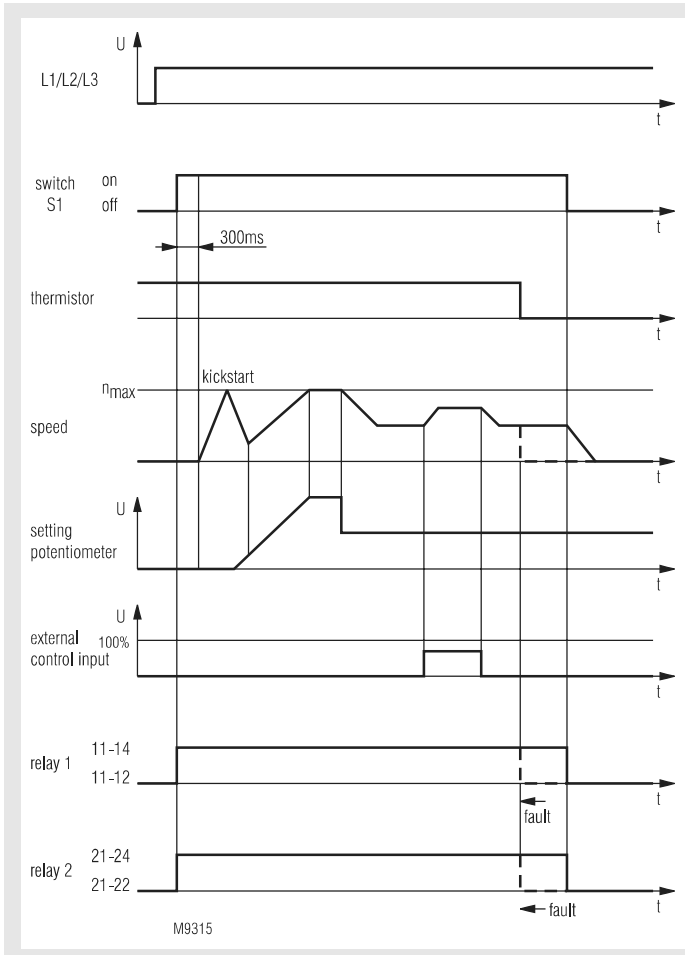

**Function**

Speed controllers are electronic devices designed to enable the speed control of 3-phase induction motors. The SX 9240 is a phase chopper device based on a thyristor circuit. The control input "Kickstart", bridge X7-X8, allows to ramp up the motor voltage to nominal value after start. After that the voltage is ramped down again to the required value with corresponding speed. The speed adjustment is made by a potentiometer on the front or by an external 0 ... 10 V input. The adjustment with the higher setting will take the control of the voltage/speed.

**Temperature sensing**

The temperature of the power semiconductors are monitored. If the permitted highest temperature is exceeded, motor, relay 1 and relay 2 are switched off. The red LED flashes code 1. This Alarm can only be reset after cooling down the device and temporarily cutting the auxiliary supply of the unit.

**Motor temperature monitoring**

A thermistor can be connected to terminals X 9 - X 10. If the permitted motor temperature is exceeded the motor, relay 1 and relay 2 are switched off. The red LED flashes code 4. The unit remains in fault status until the motor cools down and the power supply is switched off and on again. If no thermistor is connected, X 9 - X 10 must be bridged.

**Adjustment of  $U_{min}$  and  $U_{max}$**

With the potentiometers  $U_{min}$  and  $U_{max}$  the speed setting can be limited to a certain minimum and a maximum speed. The potentiometers are accessible behind a screw cover on the front of the unit.

On 400 V units the minimum voltage can be adjusted between  $110 V_{rms}$  bis  $160 V_{rms}$  and the maximum voltage between  $160 V_{rms}$  bis  $400 V_{rms}$ .

**Phase monitoring L1, L2, L3**

The phases L1, L2 and L3 are monitored internally. If one of the 3 phases fails, motor, relay 1 and relay 2 are switched off. The red LED flashes code 3. The unit remains in fault status until the failure is removed and the power supply is switched off and on again. If 2 or 3 phases fail, the unit is no longer supplied. All LEDs go off, the relays de-energise and the motor is switched off.

## Function

### Phase sequence monitoring

For normal operation a right sequence is necessary. If wrong sequence is detected, the unit goes into failure mode. The red LED flashes code 6. The unit remains in fault status until the failure is removed and the power supply is switched off and on again.

### ON-OFF switch

The ON-OFF switch is not edge triggered. If the switch is in position ON, the motor will start after the voltage is connected.

### Frequency test

When the unit is connected to voltage, the frequency is measured. If the frequency is out of the permitted limits  $50/60 \text{ Hz} \pm 10\%$ , relay 1 and relay 2 are switched off. The red LED flashes code 2. The unit remains in fault status until the failure is removed and the power supply is switched off and on again.

### Relay function

Relay 1 (11-12-14): Energises when the unit is switched on and de-energises when the unit is switched off or goes into failure mode.

Relay 2 (21-22-24): Energises when the unit is switched on and de-energises when the unit is switched off or goes into failure mode.

## Block Diagram

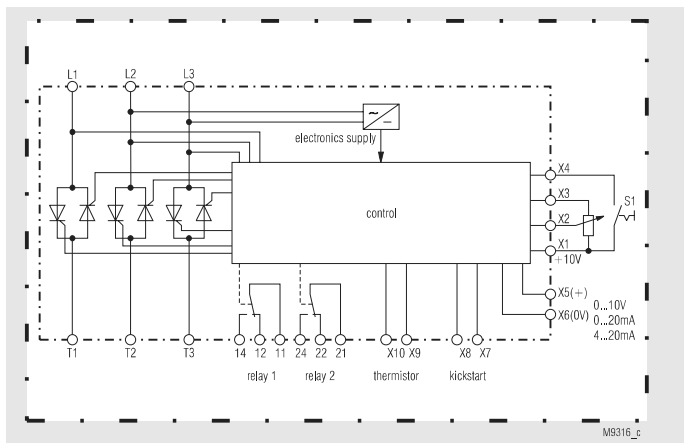

## Connection Diagrams

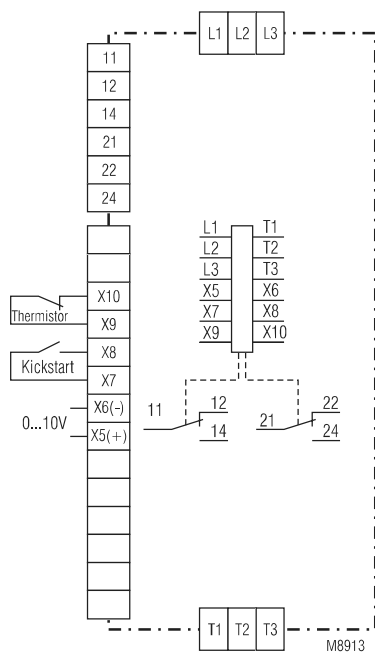

SX 9240.03/0\_005

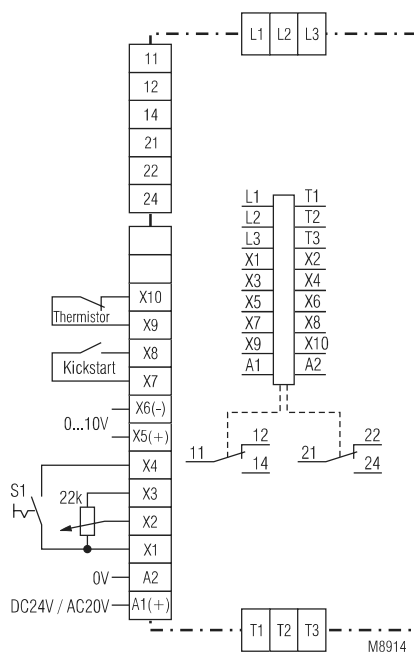

SX 9240.03/2\_015

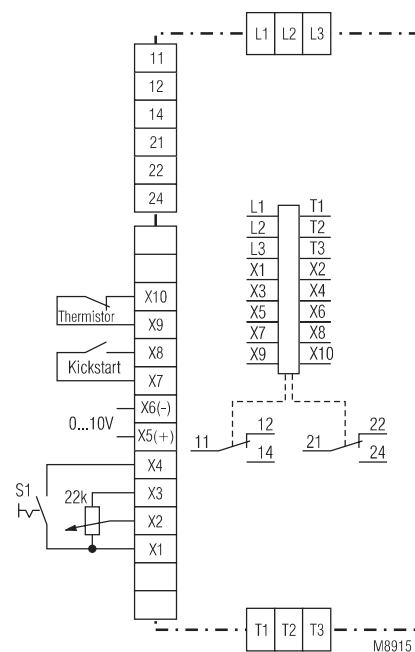

SX 9240.03/2\_005

## Indication

green LED: On, when supply connected  
yellow LED: On, when motor connected to supply voltage  
Flashing, when voltage is ramping up  
red LED: flashing code 1: power semiconductors overheated  
flashing code 2: wrong mains frequency  
flashing code 3: phase failure  
flashing code 4: motor overtemperature  
flashing code 6: wrong phase sequence

## Notes

### Protection against short circuit

It is recommended to use superfast semiconductor fuses to protect the speed controller in the case of short circuits on the output side.

### Thermal protection

The speed controllers are designed to operate motors up to the nominal load. To protect the motor against thermal overload a thermal overload device, a motor protection device or thermistor motor protection is required.

To select the right motor the following instructions must be observed:  
Between 0.6 and 1.0 of the nominal speed the current could be rise up to 50 % higher than the nominal current. This effect is caused by the voltage control. To avoid overheating of the motor it must be declassified. I.e. a 3.3 kW motor can only loaded up to 2.2 kW. In spite of this measure a higher temperature cannot be avoided. Because of this the motor should be of isolation class F or H. In addition the windings should be monitored by means of a thermal contact or thermistor for overtemperature.

### Motor noise

When the motor is running on low speed resonance can cause noise that may be disturbing.

## Technical Data

### Phase / motor voltage:

L1 - L2 - L3: 3 AC 400 V  $\pm$  10 %

**Nominal frequency:** 50 / 60 Hz

### Motor power

Type	SX 9240.03/00005	SX 9240.03/01005	SX 9240.03/02005
heat sink	without	22.5 mm	67.5 mm
power loss	10 W	20 W	50 W
Nominal current at $\vartheta_u = 40$ °C:	2.5 A	5.0 A	11.5 A
Switching cycle	continuous operation	continuous operation	continuous operation

**Min. motor power:** 0.2 W

### Ramp up time after

**Kickstart:** 7.5 s

**Hold time after Kickstart:** 1 s

### Ramp down time after

**Kickstart:** 7.5 s

**Kickstart voltage:** AC 400 V

**Power consumption:** 1.2 W

### Relay contacts

Thermal continuous current  $I_{th}$ : 5 A

### Switching capacity

to AC 15

NO contacts: 3 A / 230 V IEC/EN 60 947-5-1

NC contacts: 1 A / 230 V IEC/EN 60 947-5-1

**Semiconductor fuse:** 25 A superfast

**External control input:** 0 ... + 10 V, 0 ... 20 mA

Input impedance: 20 k $\Omega$  82,5  $\Omega$

**Reference voltage:** 10 V / 15 mA

Setting potentiometer: 22 k $\Omega$

Input impedance: 20 k $\Omega$

### Thermistor input

NC contact, switching voltage: 24 V

Input impedance: 50 k $\Omega$

## Technical Data

Ramp time: approx. 5 sec from min. speed to max. speed or max. speed to min. speed

### Variation of motor voltage

#### at AC 400 V

SX 9240.03/0\_005: 110 V<sub>eff</sub> ... 400 V<sub>eff</sub>

## General Data

**Temperature range:** 0 ... + 40°C

(If the temperature (20 ... 60°C) exceeds the a. m. range the nominal current can be increased by 2 % / °C on lower temperature or must be decreased by 2 % / °C on higher temperature.)

**Storage temperature:** - 25 ... + 75°C

### Clearance and creepage distances

rated impuls voltage /

pollution degree

Control voltage to motor

voltage: 4 kV / 2

IEC 60 664-1

Auxiliary voltage to motor

voltage: 4 kV / 2

IEC 60 664-1

### EMC

Electrostatic discharge: 8 kV (air)

IEC/EN 61 000-4-2

HF-irradiation: 10 V / m

IEC/EN 61 000-4-3

Fast transients: 2 kV

IEC/EN 61 000-4-4

Surge voltages

between

wire for power supply: 1 kV

IEC/EN 61 000-4-5

Interference suppression:

Limit value class B

EN 55 011

Radiated interference:

Limit value class B

EN 55 011

**Degree of protection:** IP 65

IEC/EN 60 529

### Vibration resistance:

Amplitude 0,35 mm

frequency 10 ... 55 Hz IEC/EN 60 068-2-6

0 / 055 / 04

IEC/EN 60 068-1

### Climate resistance:

### Terminal designation:

EN 50 005

### Wire connection

Load terminals:

4 mm<sup>2</sup> solid, or

2.5 mm<sup>2</sup> stranded

Control terminals:

1.5 mm<sup>2</sup> stranded

Relay terminals:

2.5 mm<sup>2</sup> stranded

### Net weight:

2.5 A: 1280g

5.0 A: 1500 g

11.5 A: 1680 g

## Dimensions

### Width x height x depth:

2.5 A: 100 x 160 x 165 mm

5.0 A: 122 x 160 x 165 mm

11.5 A: 168 x 160 x 165 mm

## Standard Types

SX 9240.03/01005

Article number 0059141

- 3-pole
- for motor currents up to 5 A
- with EMC-filter, Housing, ON/OFF switch and setting potentiometer
- with heat sink 22.5 mm
- Control input for 0 ... 10 V
- Thermistor input
- with internal transformer
- 122 mm width

SX 9240.03/02005

Article number 0057511

- 3-pole
- for motor currents up to 11.5 A
- with EMC-filter, Housing, ON/OFF switch and setting potentiometer
- with heat sink 67.5 mm
- Control input for 0 ... 10 V
- Thermistor input
- with internal transformer
- 168 mm width

## Variants

### Ordering example for variants

SX 9240 .03 /

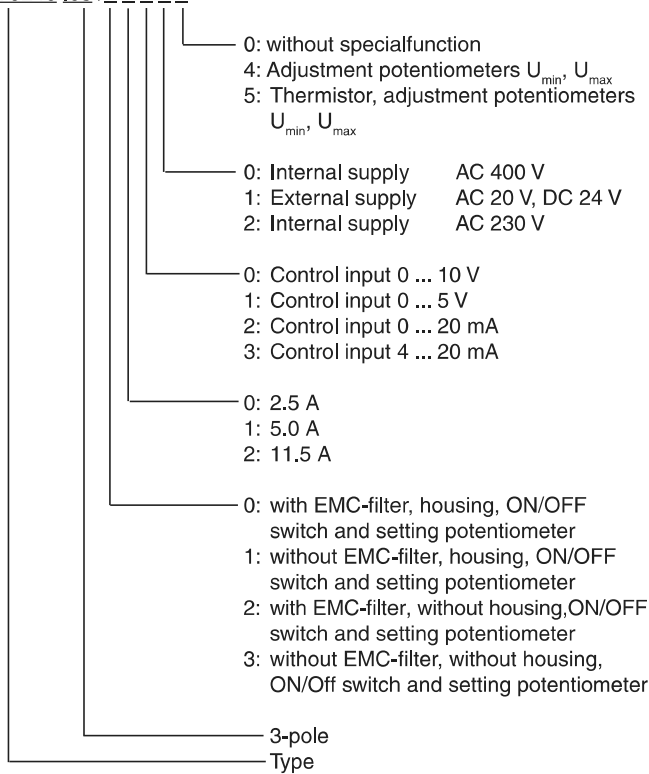

## Set-up Procedure

- 1.) Open enclosure. Connect device and motor according to circuit diagram.
- 2.) Remove bridge X8 / X7 when "Kickstart" is not required.
- 3.) Close enclosure and apply auxiliary voltage.
- 4.) Start unit with ON/OFF switch.
- 5.) Turn speed setting potentiometer fully anticlockwise. Adjust  $U_{min}$  potentiometer high enough, so that the motor starts. A humming motor at standstill should be avoided in order not to heat up the motor unnecessarily. Turn speed setting potentiometer fully clockwise. Adjust  $U_{max}$  potentiometer until the required max. speed is reached. The motor temperature should be checked on low and medium speed. If necessary the motor must be cooled.

## Safety Instructions

- Never clear fault when the device is switched on.
- Attention:** This device can be started by potential-free contact, while connected directly to the mains without contactor (see application example). Please note, that even if the motor is at rest, it is not physically separated from the mains. Because of this the motor **must** be disconnected from the mains via the corresponding manual motor starter.
- The user must ensure that the device and the necessary components are mounted and connected according to the locally applicable regulations and technical standards.
- Adjustments, e.g. adjustment of  $U_{min}$ ,  $U_{max}$  may only be carried out by qualified specialist staff and the applicable safety rules must be observed. Wiring and disconnection work must only be made when the unit is isolated from the mains.
- After disconnection of the device dangerous voltages may be sensed for several minutes on the connection terminals caused by filter capacitors.



## Application Example

