

# RGY000MBP4

## 4 ZONES GAS DETECTION CENTRAL UNIT

- 230V~ power supply
- Controls up to 4 zones
- Manages CO, L.P.G. and Methane (CH<sub>4</sub>) transmitters
- Wide parameters configuration freedom
- Last alarm conditions data retention
- LCD backlight 2 x 16 characters display
- 9 modules DIN rail mount
- Compliant with EN60079-29-1 performance standard

### [a] OPERATION, INSTALLATION AND MAINTENANCE

#### Operation

This is a microcontroller based device capable of monitoring the gas concentration in up to 4 different zones: for each of these a 4 .. 20 mA transmitter can be wired for measurement and detection of either L.P.G., Methane or Carbon Monoxide (CO).

After power-up the display shows the following information:

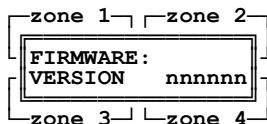

where 'nnnnnn' is the firmware version installed in the device. This information will remain visible for about 2 seconds. After this time the main information will be displayed (example):

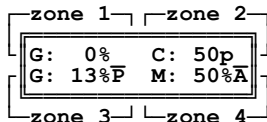

Each zone provides the following information:

The first letter from left explains the transmitter type wired to the central unit.

The transmitters which can be wired to the central unit can be different for each zone; the detectable gases are the following:

- L.P.G.: display shows letter 'G'
- Methane (CH<sub>4</sub>): display shows letter 'M'
- Carbon Monoxide: display shows letter 'C'.

Values displayed on the right, in % L.E.L. (in case L.P.G. or Methane transmitters are connected) or ppm (in case of Carbon Monoxide) are the actual gas concentration values measured by the transmitters. The last letter shown on the display for each zone indicates the actual state of the relevant transmitter as explained in the following:

- '\_': Active state (measuring, normal operation).
- 'G': Fault on the 'G'as transmitter (Iout=2 mA).
- 'F': 'F'ault over the current loop (either short or open circuit between any of the sensor wires: Iout=0 mA).
- 'P': 'P'realarm state.
- 'A': 'A'larm state. When 'OVR' is shown in place of the concentration value, this means that the upper limit of the measuring range has been exceeded. The 'OVR' state corresponds to an input current value above 20mA.

#### Prealarm and Alarm functions

The central unit can manage separately the pre-alarm and alarm conditions through two distinct, Normally Open, output relays.

In case the prealarm threshold is reached, the central unit enables the relevant relay, which, in turn, closes its output contacts.

In case the alarm threshold state is reached the unit will also enable the alarm relay thus closing the relevant output contact. At the same time the central unit has stored the pre-alarm state first and the alarm state later: the date and hour when the last has



SEITRON S.p.A. a socio unico

Via del Commercio, 9/11  
36065 MUSSOLENTE (VI) - ITALY  
Tel.: +39.0424.567842  
Fax.: +39.0424.567849  
http://www.seitron.com  
e-mail: info@seitron.it

happened will be retained in the central unit memory.

In case the gas concentration returns below the pre-alarm threshold, the relevant relay will return to its normal operation state or not, according to how the prealarm relay operating mode was set in the configuration.

**Note:** For compliance with the current performance standards the Alarm relay has always a latched operation and this mode cannot be modified by the user. Whenever either an Alarm situation ('A') or an Overrange ('OVR') situation is reached, this relay is kept energised together with the internal buzzer and the red led until the user intentionally presses for 3 seconds the 'reset' key.

#### Auxiliary relay

The central unit features one additional relay with changeover contacts (SPDT) which can be activated according to events and operating modes set by the installer through the relevant menu.

#### Display of the last alarm state

The central unit can retain the date and hour of the last alarm event happened in each zone.

This information can be read by the user at any time by pressing for 3 seconds the 'reset' key when in main display screen, then pressing '<' or '>' keys to cycle through the zones.

#### Electrical Wirings

The central unit is normally powered with 230V~ mains voltage. At terminals 6 and 7 the user can wire a battery backup system whose purpose is to grant full functionality to the central unit even in case of power failure (see section [m] for details).

Normally Closed (NC) output of the auxiliary relay is available at terminals 15 and 16, while the Normally Open (NO) one is available at terminals 16 and 17.

This output can be used either for driving 'general purpose' loads as a siren or an flashing light or, with proper configuration of the relevant parameters, to drive a gas shut-off electrovalve.

Moreover this central unit features two single pole relay contacts for each zone, one for prealarm and one for alarm.

The number of transmitters which can be wired to the central unit is 4, each compliant with the 4..20 mA current loop system.

In order to make electrical wirings please refer to the suggested wiring diagrams. Please also note that all the relay outputs of the central unit do not feed power to the loads.

In other words all outputs are 'voltage free', giving the user more freedom to use loads with several operating voltages.

#### ⚠ WARNING

- **This Central Unit is NOT approved for installation in ATEX classified zones.**
- **All wirings with remote sensors must be made using wires with 1,5 mm<sup>2</sup> minimum cross section and no longer than 25 m. Do not use same duct for signal wires and mains.**
- **In case of installation where strong EMC disturbances are present, it is highly suggested the use of shielded cables. The shield must be connected to the 'Gnd' terminal of the relevant zone on the Central Unit side only.**
- **The appliance must be wired to the electric mains through a switch capable of disconnecting all poles in compliance with the current safety standards and with a contact separation of at least 3 mm in all poles.**
- **Installation and electrical wirings of this appliance must be made by qualified technicians and in compliance with the**

current technical and safety standards.

- Before wiring the appliance be sure to turn the mains power off.
- It is up to the installer (whose responsibility is to set-up a detection system in compliance with the existing standards, both European and National) to choose the proper type of loads to connect to the central unit as well as the correct configuration of the system parameters. In case of doubts please contact the distributor.

## [b] ADJUSTMENT

In order to get access to the parameters configuration menu a password is required. The factory-set password value is '0000'. It is mandatory to modify it to prevent changes on settings from unauthorized people, as required by the performance standards.

### NOTE

- In each of the following directions, after having set a parameter:
  - Pressing the 'enter' key stores the changes into device memory.
  - Pressing the 'reset' key quits the changes without storing the changes and returns to the upper level menu.
- In every parameters configuration phase the central unit returns to the main menu whenever no activity is made on the keys for more than 15 seconds.

### Power on sequence

POWER ON



```
FIRMWARE:
VERSION  nnnnnn
```

This screen shows the current firmware version



```
G: 0%_ C: 0p_
G: 0%_ M: 0%_
```

enter > Enter pwd: 0000  
rst <> +- ent



press 'reset'  
for 3 seconds

The following screens show the last event in each zone



```
Zone1 : prealarm
12/07/10 09:20
```

Pressing '<' or '>' cycles through all zones



```
Zone2 : prealarm
12/07/10 09:20
```



```
Zone3 : prealarm
12/07/10 09:20
```



```
Zone4 : prealarm
12/07/10 09:20
```

### Configuration menus

From the main screen, showing the current state of all active zones, the user can access all configuration sub-menus which allow to change the settings of the available parameters for a proper operation of the gas detection system.

```
G: 0%_ C: 0p_
G: 0%_ M: 0%_
```

Main screen (example)



press 'enter'



```
Enter pwd: 0000
rst <> +- ent
```

Pressing '<' or '>' cycles through single digits  
Pressing '+' or '-' sets the desired value for each digit



enter password



press 'enter'



```
Zone1 management
rst <> ent
```

Pressing '<' or '>' cycles through all submenus. Press 'enter' to access the submenu



```
Zone2 management
rst <> ent
```



```
Zone3 management
rst <> ent
```



```
Zone4 management
rst <> ent
```



```
Aux relay mgmt.
rst <> ent
```

Auxiliary relay manag. screen



```
Change date/time
rst <> ent
```

Date/time settings screen



```
Change password
rst <> ent
```

Change password screen

### (Zone1 management) - Zone1 gas type

Sets the gas type for the sensor wired in Zone 1.

```
Zone1 management
rst <> ent
```



press 'enter'



```
Zone1 type: LPG
rst <> +- ent
```

Pressing '+' or '-' cycles through gas LPG - CO - MET

- LPG: Selected gas is LPG.
- CO: Selected gas is Carbon Monoxide.
- MET: Selected gas is Methane.

### (Zone1 management) - Zone1 active

Sets Zone 1 as active or inactive.

```
Zone1 management
rst <> ent
```



press 'enter', then '>'



```
Zone1 active: Y
rst <> +- ent
```

Pressing '+' or '-' cycles through 'Y' and 'N'

- Y: Zone is active, i.e. a transmitter is connected.
- N: Zone is inactive.

### (Zone1 management) - Zone1 %LEL (ppm) at full scale

Sets the full scale range for the sensor connected to Zone 1. The value that must be entered here is the full scale value (in % LEL for combustible or ppm for toxic) that the 4..20mA transmitter measures when setting its maximum current value, i.e. 20mA. This allows for the proper indication of the %LEL on the central unit display. The central unit takes care of converting proportionally all

values between 4 and 20mA into the correct value from 0% (or Oppm) to the full scale.

```
Zone1 management
rst <> ent
```

press 'enter', then '>' twice

```
Zone1 @ fs: 100%
rst <> +- ent
```

Pressing '+' or '-' cycles from 1% to 100% (LPG and MET) and from 1ppm to 999ppm (CO)

### ⚠ WARNING

- The value to set for this parameter is strictly dependant on the gas transmitter features, i.e. which value has been set as full scale (20 mA) in the transmitter at design time.
- When for a zone a CO (carbon monoxide) transmitter is selected, in order to compensate for small drifts in the zero level, the central unit will not show values within the 2.5% of the set full scale range.

#### (Zone1 management) - Zone1 pre-alarm threshold

Sets the pre-alarm threshold level for Zone 1, in % LEL for combustibile or ppm for toxic. This is the gas concentration value at which a first level of attention is needed because the environment is becoming dangerous.

```
Zone1 management
rst <> ent
```

press 'enter', then '>' 3 times

```
Zone1 pral: 100%
rst <> +- ent
```

Pressing '+' or '-' cycles from 1% to 100% (LPG and MET) and from 1ppm to 999ppm (CO)

### ⚠ WARNING

- In case the user tries to set a value for prealarm higher than that for alarm, the central unit automatically corrects the latter by raising it to the same value as the prealarm.

#### (Zone1 management) - Zone1 alarm threshold

Sets the pre-alarm threshold level for Zone 1, in % LEL for combustibile or ppm for toxic.

```
Zone1 management
rst <> ent
```

press 'enter', then '>' 4 times

```
Zone1 alarm: 100%
rst <> +- ent
```

Pressing '+' or '-' cycles from 1% to 100% (LPG and MET) and from 1ppm to 999ppm (CO)

### ⚠ WARNING

- In case the user tries to set a value for alarm lower than that for prealarm, the central unit automatically corrects the latter by lowering it to the same value as the alarm.

#### (Zone1 management) - Zone1 pre-alarm mode

Sets the pre-alarm relay retention mode (latching or non-latching). In order to reset the relay in case the latched mode has been set and the pre-alarm happened, just press for a few seconds the 'reset' key: the display will show the date and time when the prealarm was triggered.

Even in case the non-latched mode is selected, should a pre-alarm event be triggered, the relevant date and time is acquired; it can be displayed by pressing for a few seconds the 'reset' key.

```
Zone1 management
rst <> ent
```

press 'enter', then '>' 5 times

```
Zone1 pr mode: 0
rst <> +- ent
```

Pressing '+' or '-' cycles between '0' and 'L'

- 0: Pre-alarm relay is non-latched.
- L: Pre-alarm relay is latched.

### ⚠ WARNING

- The alarm relay operation for each zone is set to latched because of the performance standard requirements. This setting cannot be changed. The same is true for the over-range (OVR) condition.

#### Auxiliary relay management

Configures the auxiliary relay operation.

```
Aux relay mgmt.
rst <> ent
```

press 'enter'

```
Aux rl on: DISAB
rst <> +- ent
```

Pressing '+' or '-' cycles between 'DISAB', 'FAULT', 'PR+AL', 'ALARM', 'AL+FA'

```
Aux rl on: FAULT
rst <> +- ent
```

```
Aux rl on: PR+AL
rst <> +- ent
```

```
Aux rl on: ALARM
rst <> +- ent
```

```
Aux rl on: AL+FA
rst <> +- ent
```

- **DISAB** (disabled): the auxiliary relay operation is disabled.
- **ALARM** (alarm): the auxiliary relay is energized whenever the unit detects a concentration level above the alarm threshold for any zone.
- **FAULT** (error): when this mode is selected the auxiliary relay is energized whenever the unit detects either a fault in the transmitter or a fault in the current loop for any of the zones.
- **PR+AL** (prealarm+alarm): the auxiliary relay is energized whenever the unit detects a concentration level above the prealarm threshold (i.e. also above the 'alarm' threshold) for any zone.
- **ALARM** (alarm): the auxiliary relay is energized whenever the unit detects a concentration level above the alarm threshold for any zone.
- **AL+FA** (alarm+fault): the auxiliary relay is energized whenever the unit detects a concentration level above the alarm threshold or in case of a fault detected on any zone.

#### (Auxiliary relay management) - Auxiliary relay mode

Sets the auxiliary relay reset mode.

```
Aux relay mgmt.
rst <> ent
```

press 'enter', then '>'

**Aux rl mode: OPN**  
rst <> +- ent

Pressing '+' or '-' cycles between 'OPN' and 'LCK'

- **LCK** (locked): when the auxiliary relay is energized it remains energized even in case the triggering event is removed, i.e. the event is 'latched'. In order to reset the relay press the 'reset' button.
- **OPN** (open): when the auxiliary relay is energized and then the triggering event is removed, the relay returns to its former state, i.e. the event is not 'latched'.

#### (Auxiliary relay management) - Auxiliary relay logic

Sets the auxiliary relay logic.

**Aux relay mgmt.**  
rst <> ent

press 'enter', then '>' twice

**Aux rl mode: NOR**  
rst <> +- ent

Pressing '+' or '-' cycles between 'NOR' and 'REV'

- **NOR** (normal): any triggering event turns the relay on.
- **REV** (reverse): the relay is normally energized. In case of a triggering event the relay is de-energized. Use this mode when a 'positive safety' mode is required, because even in case of lack of power supply the relay is de-energized, thus granting a higher level of safety.

#### (Auxiliary relay management) - Auxiliary relay start

Sets the auxiliary relay start mode when power is first applied or after a power lack.

**Aux relay mgmt.**  
rst <> ent

press 'enter', then '>' 3 times

**Aux rl strt: DIS**  
rst <> +- ent

Pressing '+' or '-' cycles between 'DIS' and 'ENA'

- **DIS** (disabled): the relay is activated according to the current triggering events.
- **ENA** (enabled): the operator must start the operation by intentionally arming the system. In other words the auxiliary relay is kept indefinitely inactive (according to other mode settings) until the operator intentionally presses the 'reset' button. Choose this mode when a human intentional reset is required after a power lack.

#### Change date/time

Allows for setting of the current date and time.  
Proper adjustment for current date and hour is mandatory for the correct recording of the last alarm state.  
This adjustment must be performed when the central unit is first operated: from this moment on the unit will retain the correct date and time even in case of power lack, thanks to the internal real time clock and backup battery (allow 24h of charging time in case of first operation).

**Change date/time**  
rst <> ent

press 'enter'

**yy/mm/dd hh:mm**  
01/06/10 09:27

Pressing '<' or '>' cycles through yy,mm,dd,hh,mm  
Pressing '+' or '-' sets the desired value

press 'enter'  
to store data

#### Change password

Sets new password.  
The password is made of 4 numbers (no letters), each in the range 0 .. 9.

**Change password**  
rst <> ent

press 'enter'

**Set new pw: 1000**  
rst <> +- ent

Pressing '<' or '>' cycles through single digits  
Pressing '+' or '-' sets the desired value for each digit

press 'enter'  
stores data

#### NOTE

- **From the main screen, pressing at the same time the three keys '<', ':', '>' results in resetting the password to the factory value (i.e. 0000) without changing the configuration of the remaining parameters.**
- **From the main screen, pressing at the same time the four keys '<', ':', '>', '+' results in resetting the password to the factory value (i.e. 0000) as well as ALL other parameters.**

#### Messages on the central unit display

In the following are described the messages on the central unit display in different conditions. It is assumed that the Zone 1 has been set for Methane gas and the actual concentration is varying.

Message displayed:

zone 1 | zone 2  
M: --- \_ \_

Explanation:

'Zone inactive'

The relevant zone has not been activated. Remember that once a transmitter has been wired to an input the relevant zone must also be activated in configuration.

Message displayed:

zone 1 | zone 2  
M: 0% \_

Explanation:

'Normal operation'

This is what display shows during normal operation. Concentration detected in this example is 0% L.E.L.

Message displayed:

zone 1 | zone 2  
M: --- F

The yellow led flashes in correspondence with the symbol '▲' and the buzzer sends an intermittent tone.

Explanation:

'Fault in the current loop line'

Cable connecting the transmitter to the central unit present either a short or an open circuit failure between any of the sensor wires. Check and repair the current loop line regarding the faulty zone.

Message displayed:

zone 1 | zone 2  
M: --- G

The yellow led is turned on in correspondence with the symbol '▲' and the buzzer sends a continuous tone.

Explanation:

'Fault on the gas sensor'

The gas sensor is faulty and is setting 2mA on the current loop. Check for the faulty transmitter and, eventually, replace it with a new one.

**Message displayed:**

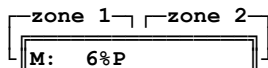

The red led flashes in correspondence with the symbol '▲' and the buzzer sends an intermittent tone.

**Explanation:** 'Prelarm state'.  
The prealarm concentration threshold in the zone under monitoring has been exceeded. In this example a prealarm threshold of 6% L.E.L. has been assumed (default factory value).

**Message displayed:**

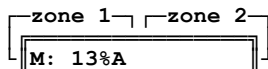

The red led is turned on in correspondence with the symbol '▲' and the buzzer sends a continuous tone.

**Explanation:** 'Alarm state'.  
The alarm concentration threshold in the zone under monitoring has been exceeded. In this example an alarm threshold of 13% L.E.L. has been assumed (default factory value).  
Alarm relay, red led and buzzer are latched as active until the reset button is pressed.

**Message displayed:**

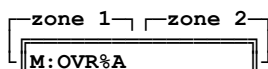

The red led is turned on in correspondence with the symbol '▲' and the buzzer sends a continuous tone.

**Explanation:** 'Over Range state'.  
The upper limit of the measuring range has been exceeded.  
Alarm relay, red led and buzzer and indication 'OVR' are latched as active until the reset button is pressed.

**Message displayed:**

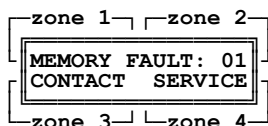

**Explanation:** 'Memory fault'.  
An error in one of the internal memories has been detected. The operation is not reliable anymore. Contact service for device replacement. Codes errors are: 01 (EEprom memory fault), 02 (Flash memory fault) and 03 (RAM memory fault).

**[c] PERIODICAL CHECK**

- A periodical check should include the following operations:
- (every 3 .. 6 months): **Functional check** of the correct operation of the entire detection system by applying calibrated gas to each remote sensor and check of the value displayed. Also refer to the sensor User Manual for further information.
  - (every 12 months): **Instrumental check** of the transfer function of the central unit and correct detection of the abnormal situations. This can be done by disconnecting the sensors from inputs and forcing through a proper calibrator the input current of each zone to the significant current values (e.g. 0mA: loop broken, 2mA: fault, 4..20mA: normal operation, >20mA: overrange).

**[d] OPERATING LIMITATIONS**

- This device can be set either for flammable gases like Methane ('M') and LPG ('G') or for toxic gases like CO ('C').
- For cross sensitivities refer to the remote sensor User Manual.
- Response time  $T_{90}$ : Not applicable.
- Temperature operating range: +5°C .. +55°C
- Humidity operating range: 20% .. 90% RH (non cond.)
- Pressure operating range: 800 .. 1100 hPa
- Power supply range: 230V~ -15% +10% 50/60 Hz
- Power absorption: 9,5VA
- Electrical wirings: See section [a].
- Batteries: See section [m].
- Sample flow rate: Not applicable.
- Warm-up time: Not applicable.
- Stabilization time: Not applicable.

- Contacts rating:
- zone relays: 8 x 2A@230V~ cosφ=1
  - auxiliary relay: 1 x 5A@250V~ cosφ=1
- Prealarm threshold range: Methane and L.P.G. 1%..100% LEL  
CO 1 .. 999 ppm
- Alarm threshold range: Methane and L.P.G. 1%..100% LEL  
CO 1 .. 999 ppm
- Protection degree: IP 00 (IP 30 in DIN rail cabinet)
- Dimensions: 158 x 90 x 71 mm (L x A x P)
- Weight: ~ 850 gr.
- ATEX protection: This device must be installed in NON-CLASSIFIED ATEX zones.

**[e] STORAGE**

- Temperature: +5°C .. +55°C.
- Humidity: 20% .. 90% RH (non cond.)
- Pressure: 800 .. 1100 hPa

**[f] % L.E.L. to % v/v conversion**

Please refer to the remote sensor User Manual.

**[g] CONTAMINANTS**

Not applicable to the Central Unit. For remote sensor please refer to the remote sensor User Manual.

**[i] SAMPLING LINES**

Not applicable.

**[j] ALARM AND FAULT SIGNALS**

Refer to sections [a] (OPERATION), [b] (ADJUSTMENT), [i] (AUTOMATIC RESET) and to Fig. 5.

**[k] TROUBLESHOOTING**

- Problem.**  
The password has been lost.  
**Remedy:**  
Proceed with password reset as explained in section [b] (ADJUSTMENT) under 'Change Password'.
- Problem.**  
One channel (zone) shows the 'F' fault message.  
**Possible cause:**  
The input current loop is broken or the transmitter is not powered.  
**Remedy:**  
Check connections between the transmitter and the central unit searching for interruptions. Check also with a multimeter for the presence of a voltage around 12Vdc between terminals '+V' and 'Gnd' of the relevant zone.

**[l] AUTOMATIC RESET**

- Pre-alarm relays action could be 'auto-resetting' in case the latching parameter (under Zone management - Zone pre-alarm mode) has been set to 'O' (open). Please refer to proper section for further details.
- Auxiliary relay action could be 'auto-resetting' in case the latching parameter (under Auxiliary relay management - Auxiliary relay mode) has been set to 'OPN' (open). Please refer to proper section for further details.

**[m] BATTERIES MAINTENANCE**

This central unit features input terminals (6 and 7) for an external 12Vdc power backup. Nonetheless it does not provide any recharging function. This means that an external unit capable of both providing 12V and recharging function for its battery must be

wired in case a power lack tolerant system is required. In the diagrams provided in this User Manual the device ACC SGB 12 has been used as an example. The battery maintenance operations must be based on what the manufacturer of this additional device suggests.

**[n] SPARE PARTS**

This central unit has no user serviceable parts.

**[o] ACCESSORIES**

This central unit has no accessories.

**[p] MARKING**

Transmitter CE Type Certificate: BVI 11 ATEX 0000  
 The above mentioned CE Type Certificate has been issued for a system composed of this Central Unit (RGY000MBP4) and 4..20mA remote Gas Sensors (SGYME0V4XD).

Manufacturer address	
Serial Number and manufacturing Year	
Operating voltage	Performance standard to which the compliance is declared
Type designation	
Oseitron Via del Commercio, 9/11 36065 Mussolente (VI) - ITALY Made in Italy U: 230V~ 50 .. 60Hz -15% +10% Input: 4 .. 20 mA Type: RGY000MBP4SE EN 60079-29-1 Pmax: 9.5VA SN: 18120149 Year: 2018 Tamb: +5 .. +55°C IP rating: IP30 Zone relays: 2A@230Vac cosφ=1 Auxiliary relays: 5A@250Vac cosφ=1	
Class II Marking	ATEX Marking
Notified Body responsible for CE Type Approval and Certificate number	
Number of Notified Body responsible for Quality System	

**Fig. 1: Marking label example.**

**⚠ WARNING**

- This Central Unit is **NOT** approved for installation in ATEX classified zones.

**[q] ADDITIONAL INFORMATION**

No additional information regarding any special nature of the device is needed.

In the view of a constant development of their products, the manufacturer reserves the right for changing technical data and features without prior notice. The consumer is guaranteed against any lack of conformity according to the European Directive 1999/44/EC as well as to the manufacturer's document about the warranty policy. The full text of warranty is available on request from the seller.

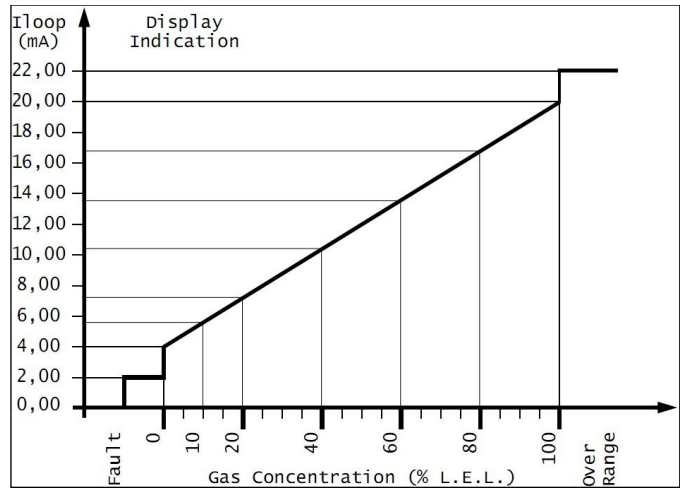

**Fig. 2. Display concentration vs. Input Current - 100% L.E.L.**

This chart is valid for the use of a 4..20mA transmitter which delivers 20mA in correspondence of 100% L.E.L.. Setting of the parameter 'Zone- @ fs' must be 100% L.E.L..

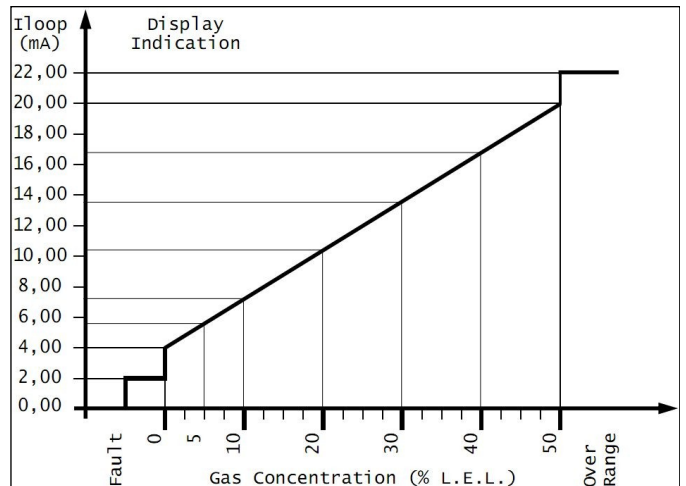

**Fig. 3. Display concentration vs. Input Current - 50% L.E.L.**

This chart is valid for the use of a 4..20mA transmitter which delivers 20mA in correspondence of 50% L.E.L.. Setting of the parameter 'Zone- @ fs' must be 50% L.E.L..

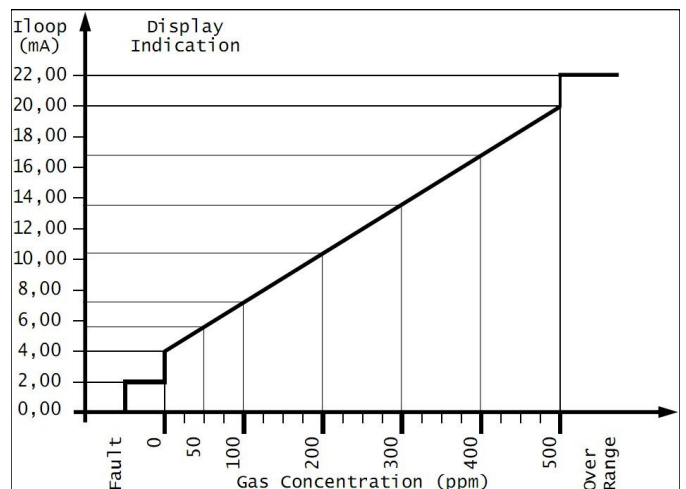

**Fig. 4. Display concentration vs. Input Current - 500ppm.**

This chart is valid for the use of a 4..20mA transmitter which delivers 20mA in correspondence of 500ppm. Setting of the parameter 'Zone- @ fs' must be 500ppm.

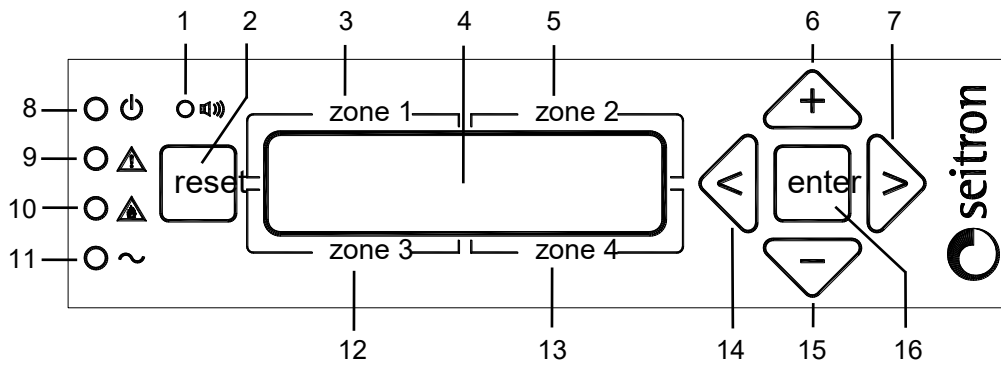

**Fig. 5. Front panel - Keyboard explanation**

1. **Buzzer.** Inside the central unit a buzzer is mounted which is activated any time an abnormal situation is detected.
2. **Reset button.** This key features two functions:
  - Quits the current menu and returns to the upper level menu.
  - When depressed more than 3 seconds, it shows the last alarm or prealarm that happened in all zones.
3. **Zone 1 display area.** In this area the user can read the actual gas concentration, the gas type for which the zone has been programmed and the presence of any abnormal situation like pre-alarm, alarm, fault or overrange (please refer to proper section for in depth description of the messages).
4. **Display.** Through this 16 characters by 2 lines display all messages are shown to the user.
5. **Zone 2 display area.** Same as point 3. but for Zone 2.
6. **Increase button.** This key is used during configuration to increase values in numeric fields as well as to cycle through different options for a given parameter.
7. **Shift right button.** This key is used during configuration to move to the next submenu.
8. **On-Off indicator.** This indicator shows the presence of power supply for the central unit, either from mains or from the eventual battery backup system.
9. **Fault indicator.** This indicator shows the presence of a fault in a remote sensor or in the wiring to the central unit. Refer to proper section for explanation of the possible causes of fault.
10. **Alarm indicator.** This indicator shows the presence of an alarm or overrange in the system. The indicator flashes in case of pre-alarm condition, while is steadily turned on in case of alarm or overrange. Refer to proper section for further details.
11. **Mains indicator.** This indicator is turned on when mains power is present. Together with On-Off indicator shows whether the unit is working with mains power or battery backup power.
12. **Zone 3 display area.** Same as point 3. but for Zone 3.
13. **Zone 4 display area.** Same as point 3. but for Zone 4.
14. **Shift left button.** This key is used during configuration to move to previous submenu.
15. **Decrease button.** This key is used during configuration to decrease values in numeric fields as well as to cycle through different options for a given parameter.
16. **Enter button.** This key, when in configuration mode, allows to enter the various menus and to confirm the selected parameter.

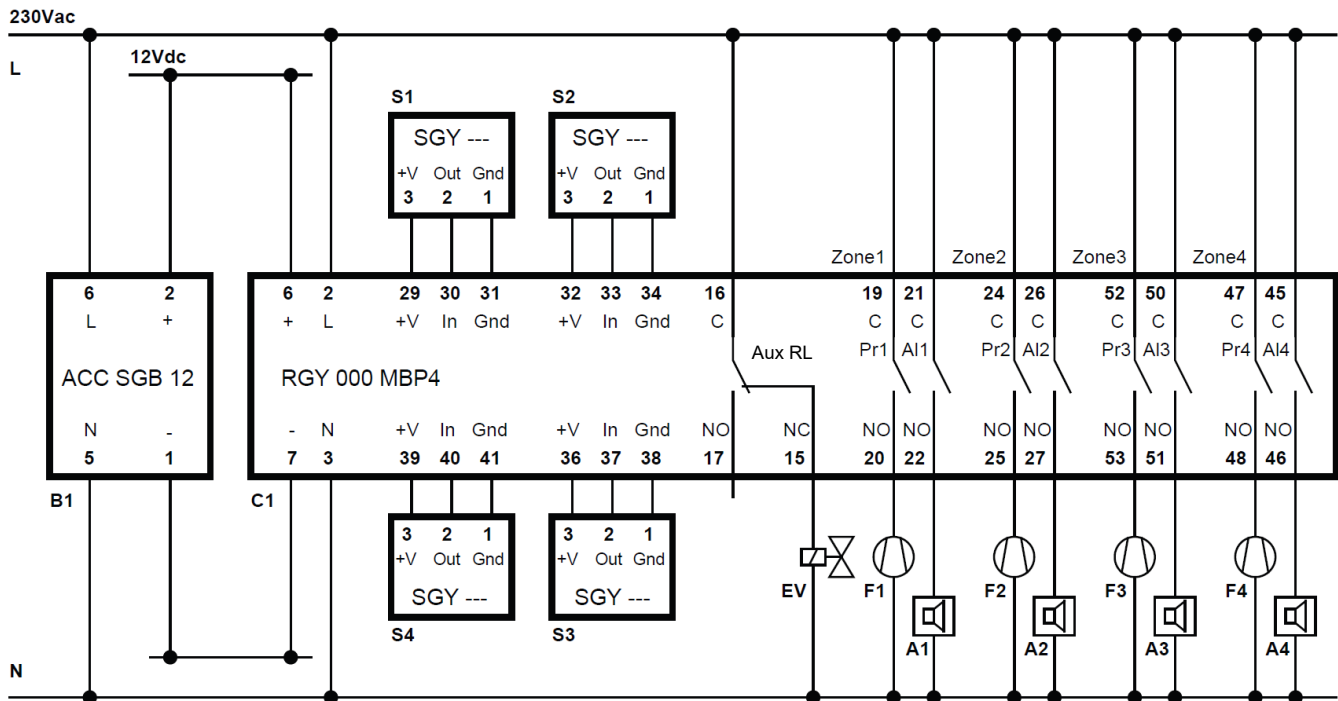

**Fig. 6. Wiring example with 230Vac NC electrovalve.**

- C1:** Central unit. Type RGY 000 MBP 4.
- B1:** Battery backup system. This device must be capable of supplying energy to the central unit in case of power lack. In this diagram type ACC SGB12 has been used.
- EV:** Gas shut-off electrovalve (230Vac). This wiring diagram is valid for Normally Closed type electrovalve.
- S1..S4:** Gas sensors. In this diagram remote sensors of the SGY--- series are used (please refer to the sensor User Manual for additional informations).

- F1..F4:** Air extractors (230Vac). These are activated when the pre-alarm relay in each single zone is activated.
- A1..A4:** Acoustic sirens (230Vac). These are activated when the alarm relay in each single zone is activated.
- AuxRL:** Auxiliary relay
- Pr1..Pr4:** Pre-alarm relays. Refer to proper paragraph for additional informations.
- Al1..Al4:** Alarm relays. Refer to proper paragraph for additional informations.

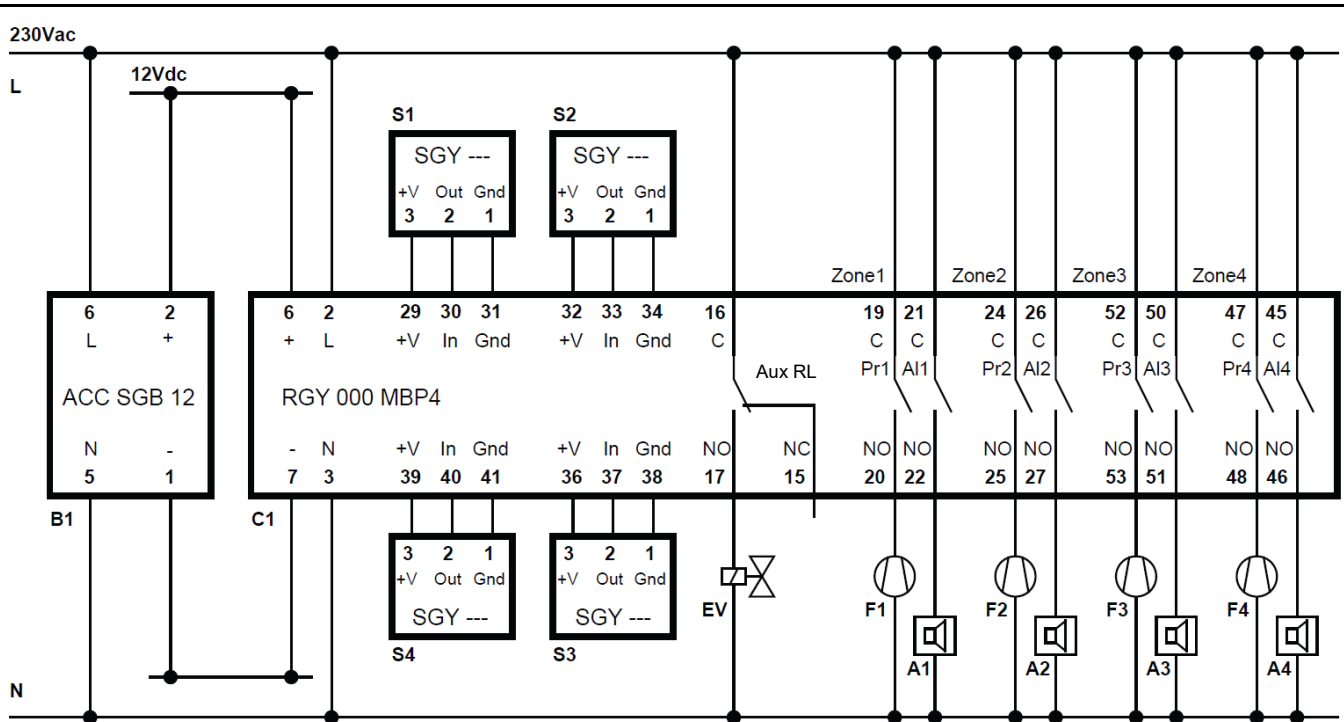

**Fig. 7. Wiring example with 230Vac NC electrovalve.**

- C1:** Central unit. Type RGY 000 MBP 4.
- B1:** Battery backup system. This device must be capable of supplying energy to the central unit in case of power lack. In this diagram type ACC SGB12 has been used.
- EV:** Gas shut-off electrovalve (230Vac). This wiring diagram is valid for Normally Closed type electrovalve.
- S1..S4:** Gas sensors. In this diagram remote sensors of the SGY--- series are used (please refer to the sensor User Manual for additional informations).
- F1..F4:** Air extractors (230Vac). These are activated when the pre-alarm relay in each single zone is activated.

- A1..A4:** Acoustic sirens (230Vac). These are activated when the alarm relay in each single zone is activated.
- AuxRL:** Auxiliary relay
- Pr1..Pr4:** Pre-alarm relays. Refer to proper paragraph for additional informations.
- Al1..Al4:** Alarm relays. Refer to proper paragraph for additional informations.
- NOTE:** This diagram features a 'positive safety'. For proper operation the parameter 'Auxiliary relay logic' must be set to 'REV' so that any lack of power would result in the relay opening and valve deactivation.

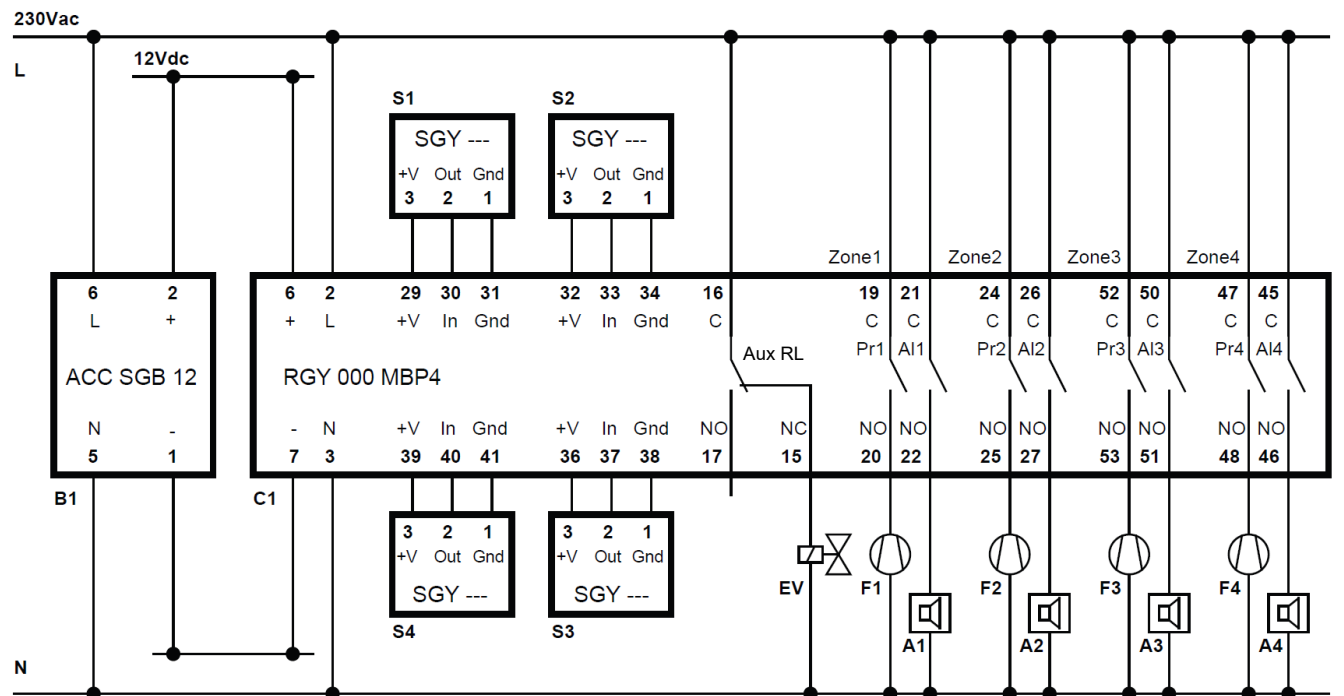

**Fig. 8. Wiring example with 12Vdc NC electrovalve.**

- C1:** Central unit. Type RGY 000 MBP 4.
- B1:** Battery backup system. This device must be capable of supplying energy to the central unit in case of power lack. In this diagram type ACC SGB12 has been used.
- EV:** Gas shut-off electrovalve (12Vdc). This wiring diagram is valid for Normally Closed type electrovalve.
- S1..S4:** Gas sensors. In this diagram remote sensors of the SGY--- series are used (please refer to the sensor User Manual for additional informations).

- F1..F4:** Air extractors (230Vac). These are activated when the pre-alarm relay in each single zone is activated.
- A1..A4:** Acoustic sirens (230Vac). These are activated when the alarm relay in each single zone is activated.
- AuxRL:** Auxiliary relay
- Pr1..Pr4:** Pre-alarm relays. Refer to proper paragraph for additional informations.
- Al1..Al4:** Alarm relays. Refer to proper paragraph for additional informations.